

Product Data Sheet

FPB23572

Listed Power Splicer Block
 175 Amps, 600 Volts UL (AC/DC)



Wire Range:

Line side: (1) 2/0 - #14 AWG
 Load Side: (1) 2/0 - #14 AWG

Electrical Ratings:

- 175A copper wire, 135A aluminum wire (Based on NEC Table 310-16, 75°C columns)
- CE Rated Voltage (U_i): 1,000 V AC/DC per IEC 60947-7-1
- 600 Volts AC/DC (Service Equipment according to National Electrical Code, NFPA 70)
- Minimum enclosure size: 16 X 12 X 6
- Factory and Field Wiring

NOTE: Use outside these ratings must be judged in end-use application

Short Circuit Current Ratings (Copper wire only):

Suitable Conductors (kcmil/AWG)		Overcurrent Protection Fuse Required Class/Max Amp Rating						SCCR, RMS SYM Amps	Volts Max
Line	Load	J	T	RK1	RK5	G	CC		
2/0 - 6	2/0 - 6	200	200	200	100	60	30	100,000	600

		Overcurrent Protection Circuit Breaker Required			SCCR, RMS SYM Amps	Volts Max
Line	Load	Mfr	Type	Max Amp		
2/0 - 2	2/0 - 2	Square D	JLL36250	250	65,000	480

Mechanical Ratings:

- Insulator base temperature: -40°C/F 125°C (257°F) UL RTI
- Maximum insulator base plate temperature: 130°C (266°F) UL RTI
- Flammability rating of insulator base: UL 94 V-0

Materials:

- Connector: High conductivity aluminum, tin plated
- Insulator base: Glass filled polycarbonate (thermoplastic)
- Terminal set screws: Aluminum, tin plated
- Mounting screws: Steel, zinc plated
- Insulator base plate: Phenolic laminate

Agency Approvals:

- UL Listed, File No. QPQS.E309401
- Investigated to UL 1953
- UL 508A Feeder Circuit Terminal Spacing for up to 600 Volts
- CSA Certified, CSA C22.2 No. 158, File No LR 19766
- 600V Rating for Class 6228 01 – Use Groups A, B, C
- CE compliant to IEC 60947-7-1
- RoHS Compliant

Wire Ranges:

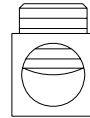

Line and Load Side Wire Range:

Wire Size	Torque		Copper Wire Stranding Classes - Number of Conductors		
	N.m	in. lbs	Solid	Class B	Class C
2/0 AWG	13.6	120		1	1
1/0	13.6	120		1	1
1	13.6	120		1	1
2	13.6	120		1	1
4	13.6	120		1	1
6	13.6	120		1	1
8	4.5	40		1	1
10	4.0	35	1	1	1
12	4.0	35	1	1	1
14	4.0	35	1	1	1

Aluminum stranded wire range: 2/0 – 14 AWG

- Wire strip length –11/16”
- Wire strip length, load side tap, top row - 3/8”, bottom row - 13/16”
- Hex key needed: 5/16”

Mounting:

- Panel mountable: #10 fastener, torque to 25-30 in. lbs.

Accessories:

- Marker Strips to mark circuits. Printing available. Consult factory.

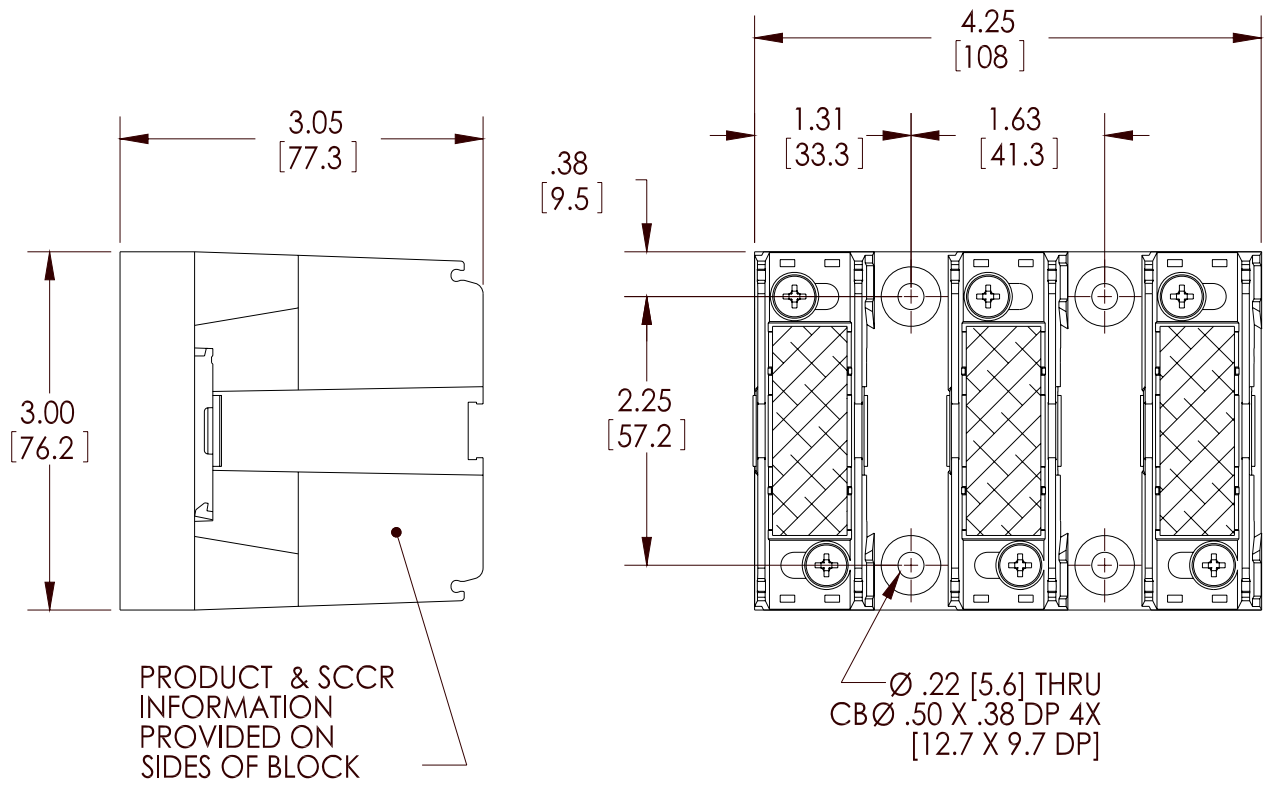

WWW.MARATHONSP.COM
1-419-352-8441